

Operations Management Exercise 4--Queuing and Simulation

The book makes this topic more complicated than it needs to be for our purposes. the topic can be simplified substantially by using tables rather than calculations, and even more by using POM-Win and EXTEND.

To simplify, we'll only consider Queues that are

- One-step process
- FIFO discipline
- Poisson arrival distribution
- Exponential Service time distribution
- Infinite source of customers

Criteria /goals for a good queue design

- reduced waiting time
- reduced queue length
- less customer time in the system

Application of EXTEND LT to a queuing problem

After playing with this a little, I'm not sure about the absolute results from the EXTEND queuing model. The one I've set up (Macdog.mox) has initially an arrival rate of 30 per hour for an average arrival interval of 2 minutes and a service rate of 30 per hour with one server, constant service (delay) time of 2 minutes. Theoretically, this should be an exploding queue, but that isn't what happens. This makes me think I'm overlooking something. Nevertheless, we can use this as an experimental model and may be able to draw some conclusions from the relative results.

Tutorials

With a little hunting around on the CD you will find a large collection of video demos and examples. You can either install the newer Version 6 from the CD ROM Extend Install directory, or run version 4 directly from the CD by executing extendLT.exe from the pomextvido3/extendlt directory. If you install it, you can open *getting started* and watch at least the tutorials on discrete event models and animation.

Experiment 1: Constant vs. variable service time

You can either open Macdog2.mox from the CD or download the model from the website by shift click or right click on the link. Start EXTEND and open the Macdog.mox model. The model is initially set up to give an arrival rate of 30 per hour. Check this by double-clicking the generator and observe that it has an exponential distribution with an arrival interval of 2 minutes. The generator produces customers and feeds them into the FIFO queue block. The queue results are fed to averaging blocks that keep track of average line length and waiting time over repeated trials.

Click on run/ simulation setup to see that the time unit is set to minutes, each simulation goes for 120 minutes, and a simulation runs the 120 minute queuing model for 100 repetitions. Double-clicking the server (delay) block will allow you to see the activity delay is initially set for a constant 2 minutes. only one of the servers is connected to the queue output. Just to get a feel for how much variation there is in these, you should run the 100 rep experiments three times and record the results. Run the model 3 times and at the end of each run, double-click the mean and variance blocks and record just the averages for queue length and waiting time for each of the three runs. Notice there is a large variation in the results.

After recording these results, connect the random number generator to the Delay connector on the delay block and perform three more runs, recording the same results for average queue length and waiting time. The random number generator will keep the same average service time (delay) of two minutes, but adds random variation that fits an Erlang distribution. You can see this by double-clicking on the random number generator. Theoretically, a fixed time service should give about half the Lq compared to variable time service.

You can check **Show animation** under the run menu to make sure things are working right. This is always good to help the Vice presidents understand it, but the display drastically slows down the simulation, so you will want to do the studies with animation turned off. In the event your simulation runs amok, use stop under the run menu.

Experiment 2: Service increase to two servers

Connect the queue output to the second server as well. This one is already set up with the random number generator. Rerun the model three more times and note how additional service capacity drastically reduces waiting lines and waiting times.

Experiment 3: Effect of combining queues

Set up a second generator, queue and server so you can run two one-server systems in parallel. The easy way is to copy

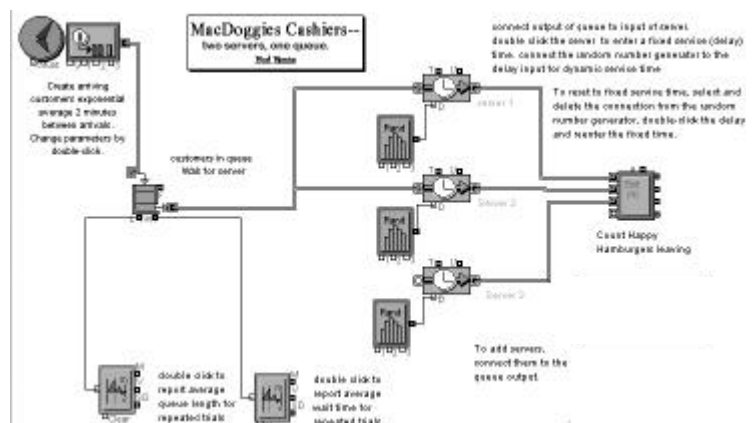

and paste to duplicate the objects, then hook them together in the required configurations. Gather data from both on line length and average wait times. Do this for 3X100X120 minutes and calculate averages for each system. The total number of people standing in line would be the sum of the two average Lq's. The average wait time is percustomer, so you just take an average of the two averages for Wq. Compare this to what would happen if you combine the two queues. This can be done most easily by using only one generator and one queue with two servers as in experiment 2, but increase the arrival rate to 60 perhour by reducing interarrival time from two minutes to one minute.

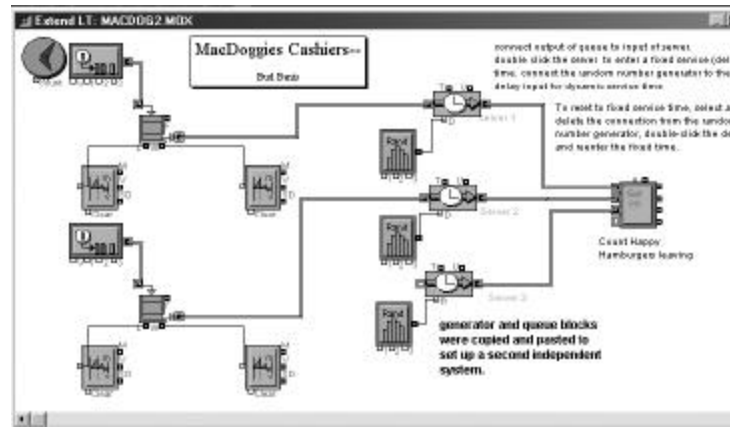

This simulates a combination of two queues with arrival rates of 30 per hour. Now the combined arrival rate is one per minute or 60 per hour, feeding two servers, depending on which is free. Compare the Lq and Wq to those for the two independent single-server queues with arrival rates of 30. What you should see, if experimental variation allows, is a less-than doubling of the queue length and a substantial reduction in average waiting time for the customers. This effect is why serpentine combined queues have become so prevalent in places like banks and airports in the last 15 years. This is operations management at work improving our lives!

Report

Make sure you replace my name with yours. Print out the diagram of the model after modifying to two separate queues. the easiest way to do this is via the **PrintScrn** button to capture the screen on the clipboard, then paste into WORD or EXCEL. Also print out some data after double-clicking the report average queue length module. This data must correspond to one of the results reported in your short report below. Include a screen capture in a short one-page report with tables of means (don't show variance or s.d.) showing queue length and waiting times for each of the triplicate experiments and write a few sentences commenting on the significance of the results of each experiment. **Everyone must report their own data and conclusions.**

yourname
Section time

Use all print screen to capture the active window to the clipboard, paste into EXCEL and then adjust size.
Use print/print preview/ setup print to one page and make it landscape or portrait to give a legible one page report

Expt 1 --fixed vs variable service time (you might want to repeat this rather than just reporting what we got in class to confirm you understand.)

	fixed		variable		
	Lq	Wq	Lq	Wq	
1	3.7	6.68	4.55	7.41	
2	3.7	6.47	4.89	7.93	
3	3.88	6.79	4.23	6.85	
avg	3.76	6.65	4.56	7.40	

Results
for the same service time on avg, variable time gave a longer lq and higher wq. Anything you can do to reduce variance and standardize a process gives higher efficiency.

Expt 2--add a second server

	M=1		M=2	
	Lq	Wq	Lq	Wq
1	4.55	7.41		
2	4.89	7.93		
3	4.23	6.85		
avg	4.56	7.40		

Results

Expt 3--combining queues

system 1	independent		combined queues M=2, lambda=60, Mu=30	
	Lq	Wq	Lq	Wq
1				
2				
3				
avg				
system2				
1				
2				
3				
avg				

Results:
make a text box by view toolbars drawing then click on the icon that is a box with an "A" in it. You can draw the textbox anyplace you want as well as move it around later. There is no need for this report to be more than one page.
capture the screen by printscrn then paste into the sheet.

Lq added Wq avgd